

Flat-white LED

EWL5FW12

Neutral White Light-emitting Diode

Flat-white LED is a neutral white solid-state light emitter. Its spectrum is maximally flat. The white light emission from this device has no color bias i.e. the light is neither warm white nor cold white. The flat-white light emission from this LED makes it suitable for high CRI illumination applications and as backlights for display applications. The device is available in 100 mW surface mount low-power as well as 1W and 3W power LED packages.



Typical Applications

- High CRI (>96) white lighting
- Display backlights
- Photography
- Spectroscopy
- Optical instrumentation

Key Features

- Neutral white light emission with no color bias
- Lead free and RoHS compliant
- ESD and reverse voltage protection

Principal Parameters

Forward voltage drop (at 200 mA): 3.0 V
 Emission wavelength peaks: 638 nm, 548 nm and 458 nm
 Nominal correlated color temperature (CCT): 6162 K
 Emission angle: 120°
 Typical CIE chromaticity coordinates: 0.32 (x), 0.33 (y)
 Typical luminous intensity (low power LED): 6500 mcd
 Typical luminous intensity (high power LED): 72 Lumens
 Typical operating current (low power LED): 20 mA
 Typical operating current (high power LED): 250 mA
 Operating temperature range: -40 °C to 80 °C
 Lifetime (continuous use): 20,000 hours
 Lens geometry: Round

Absolute Maximum Ratings

Maximum continuous operating Current (low power LED): 30 mA
 Maximum continuous operating Current (high power LED): 300 mA
 Maximum power dissipation (low power LED): 100 mW
 Maximum power dissipation (high power LED): 1W
 Maximum reverse voltage: 5 V
 Maximum soldering temperature: 260 °C for 5 sec

Packaging: EWL5FW12 is available in low power (SMD 3528) and high power LED surface mount device packages. See pages 5 & 6 for device package and availability information.

Electrical and Optical Characteristics

Current-voltage characteristics

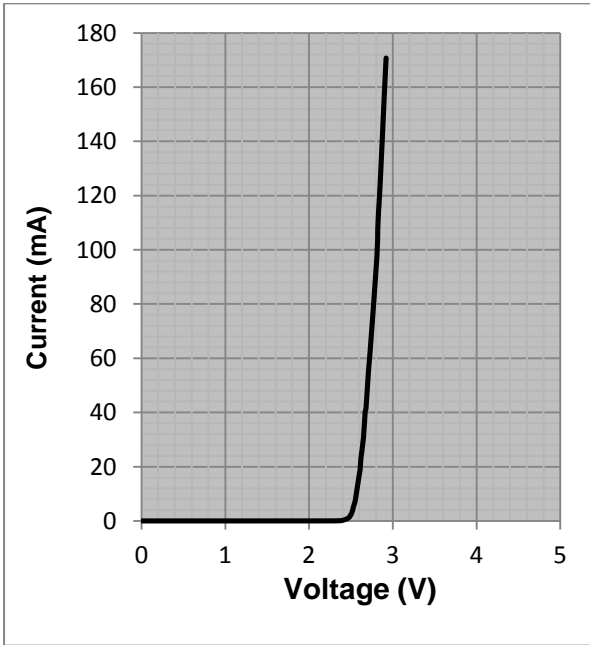

Light intensity versus LED drive current

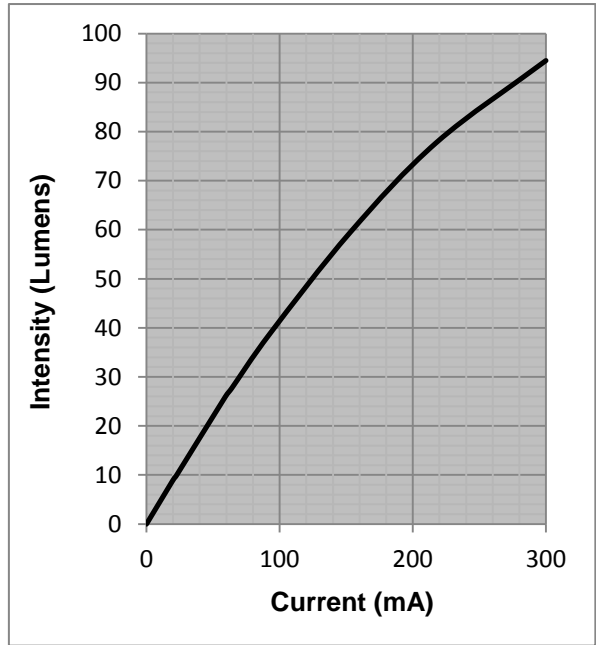

Optical spectrum

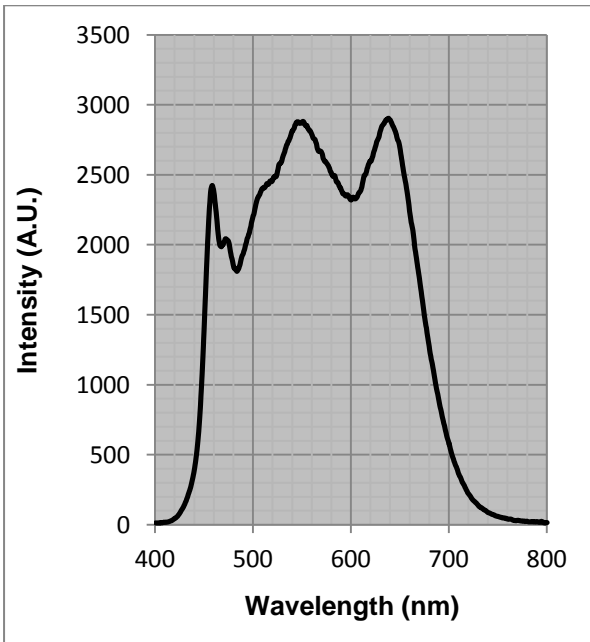

Angular light emission pattern

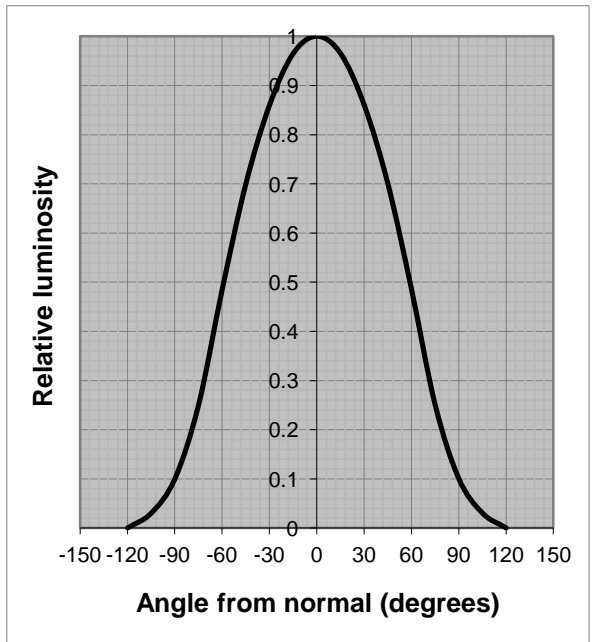

CIE Chromaticity Diagram

(Measured at 20 mA drive current at 25 °C LED junction temperature)

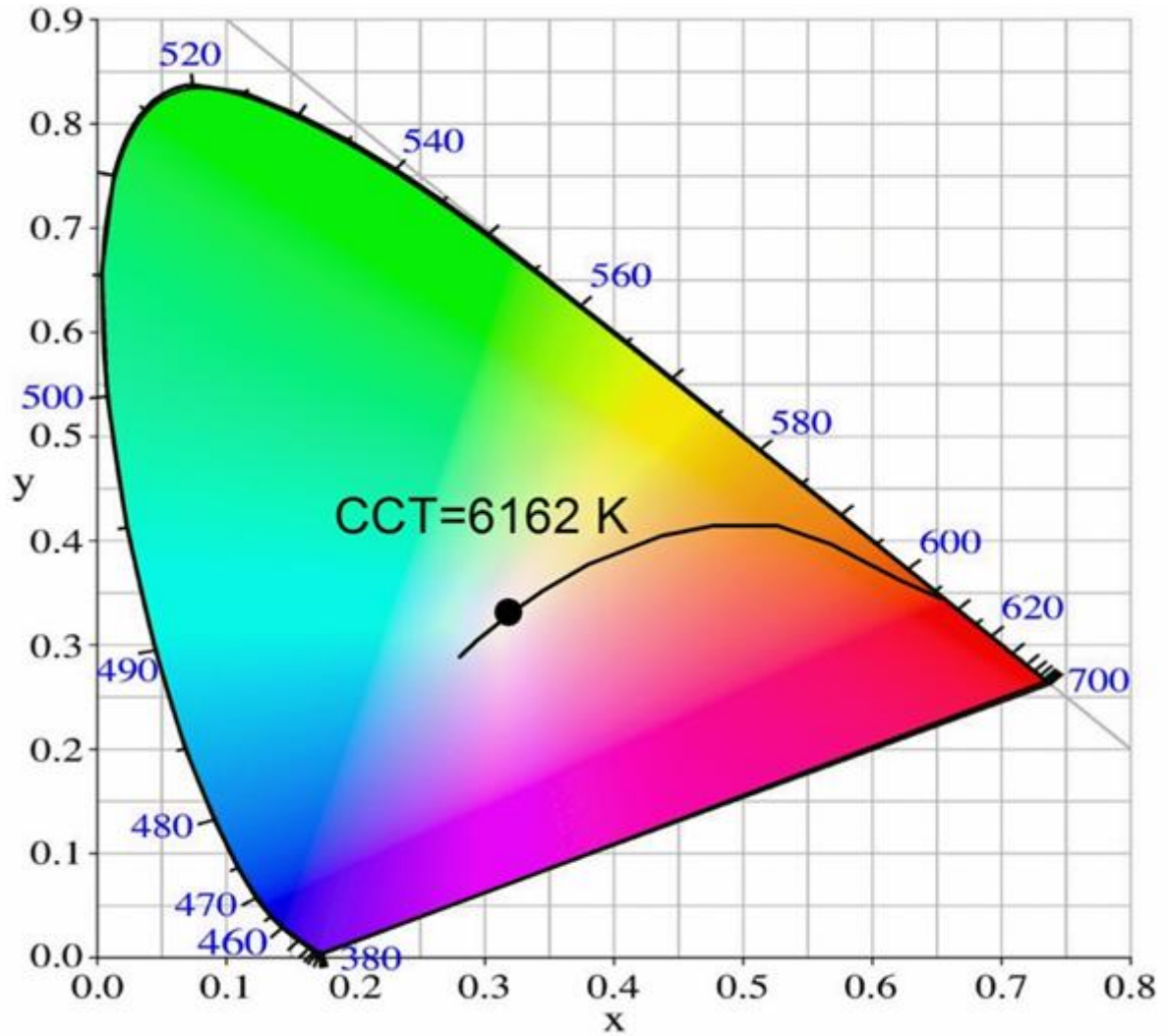

CIE chromaticity coordinates: X = 0.318941 Y = 0.331052

Application Information

General

Electrospell Flat-white LEDs can be operated in both continuous and pulsed modes. The latter may be more power-efficient in certain applications. Like other LEDs, these devices start emitting light once their forward voltage drop exceeds their emission threshold. Thereafter, the light continues to increase in intensity as the drive current increases. The output optical power begins to saturate at high drive currents due to carrier saturation and thermal effects. This saturation is reached at lower currents when the device is operated at higher ambient temperatures. Adequate heat sinking must be provided to ensure satisfactory performance in terms of optical output, lumens maintenance and device lifetime. See more about this in the Design Considerations section below.

Analog Drive

Flat-white LEDs can be driven by a continuous current drive. A stable, high internal impedance current source is recommended for this purpose. There are both fixed and variable current sources commercially available that are suitable for this purpose. Fixed current sources, such as the NSI45030AT1G from ON Semiconductor provide a set current through an LED whereas the current output from a variable source, such as the PSSI2021SAY from NXP or the LM134 from Linear Technology can be adjusted using a trimming resistor. The current drive from all these and other similar devices is stable enough to drive Flat-white LEDs at constant brightness.

Digital Drive

For more precise intensity control, Flat-white LEDs can be driven by a digital pulse width modulation (PWM) signal. Generally, 8 bit precision is sufficient for most applications but if needed 10 or 16 bit systems can also be implemented.

This approach requires the use of either a microcontroller or a dedicated PWM generator. Most general-purpose microcontrollers are suitable for this application although some manufacturers also offer devices optimised for lighting control. Please note that digital drive requires a MOSFET power driver external to the microcontroller in order to handle the drive current requirements of Flat-white LEDs. Electrospell can provide details of a reference design based on Atmel AVR 8-bit microcontrollers.

Design Considerations

Good electrical, thermal and optical designs are the keys to obtaining good performance from LEDs. Please make sure that stable, noise-free power is provided to these LEDs for best performance and long operating life. Also make sure that printed circuit board (PCB) tracks are wide and thick enough to handle current fed to LEDs. These devices should be mounted with proper heat sinking if they are to be driven at high power levels. Operating them at temperatures below 60 °C is highly recommended for long life and spectrum maintenance. Placing the LED package body on a metal core PCB (MC-PCB) or in contact with a metal heat sink is recommended. Filling the space between the LED and the heat sink with a suitable thermal interface material, such as Thermotime, is also recommended. Please note that significant increase of LED temperature can lead to reduced performance and premature failure. Flat-white LEDs emit light in a circularly symmetric Lambertian pattern with most light emitted normal to the device and the intensity falling at larger angles from the normal according to a cosine distribution function. In order to collect the maximum amount of light, proper reflectors should be used. These could be a feature of the product housing or can be inserted as accessory components. Proper choice and placement of reflector can maximise the amount of light that can be obtained from a lighting system.

Circuit Examples

A simple resistor-connected circuit such as the one shown below can be used to drive Flat-white LEDs. Use a resistor with a suitable power rating.

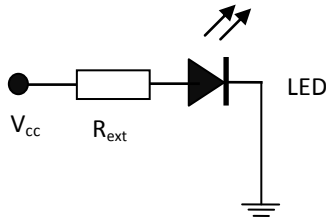

For better performance, where the supply voltage can change, use of constant current sources is recommended. The PSSI202SAY constant current IC can be used for this purpose for currents up to 50 mA, as shown below. Please refer to the PSSI202SAY datasheet for further information. For higher currents, use a transistor-based constant current source.

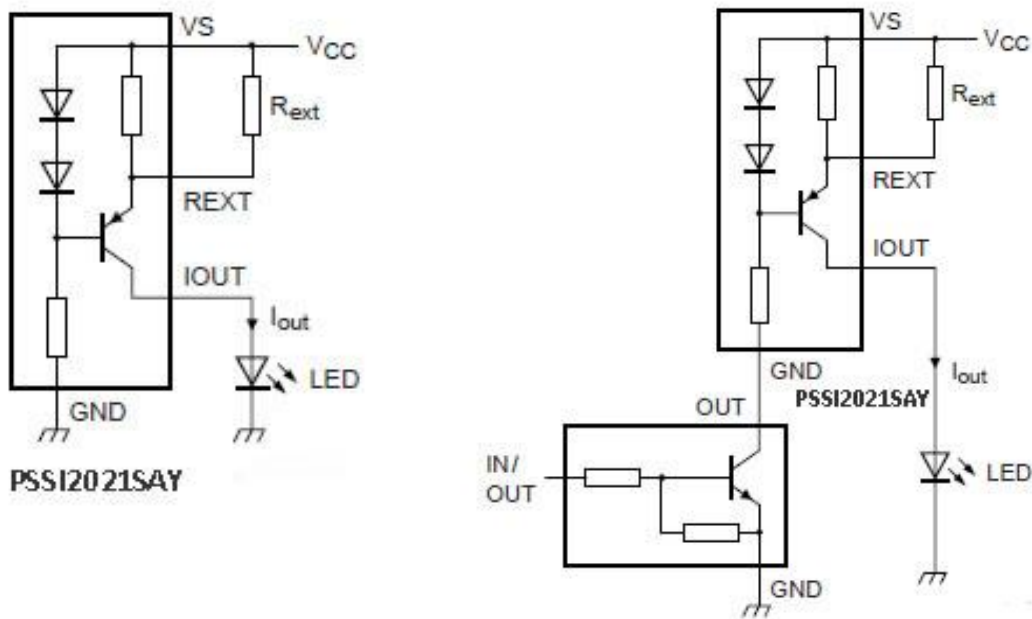

For digital PWM drive, a power interface circuit using a MOSFET such as IRFZ34 and a MOSFET driver such as LT1910 are needed. Please contact ElectrosPELL for further information about LED drive electronics.

SMD PLCC (3528) Package Drawing - All dimensions are in mm

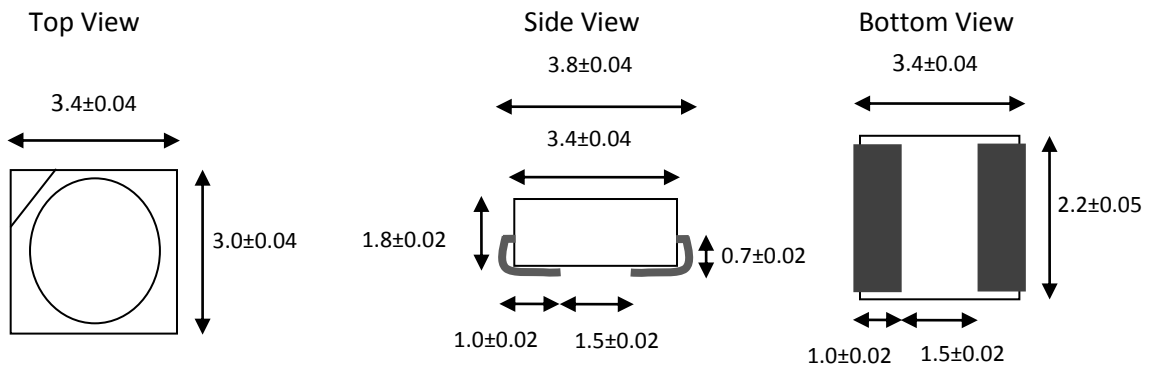

Emitting Aperture Diameter: 2.4 mm

1W and 3W* Power Package Drawing - All dimensions are in mm

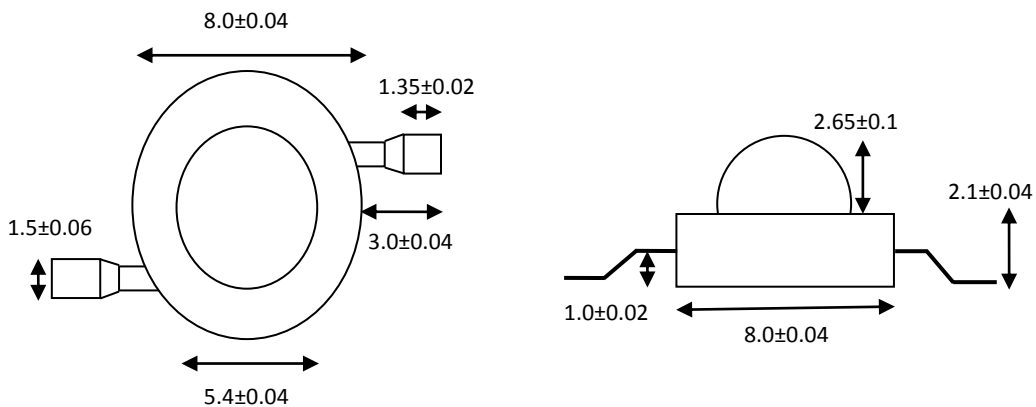

Recommended land patterns for SMD and power packages

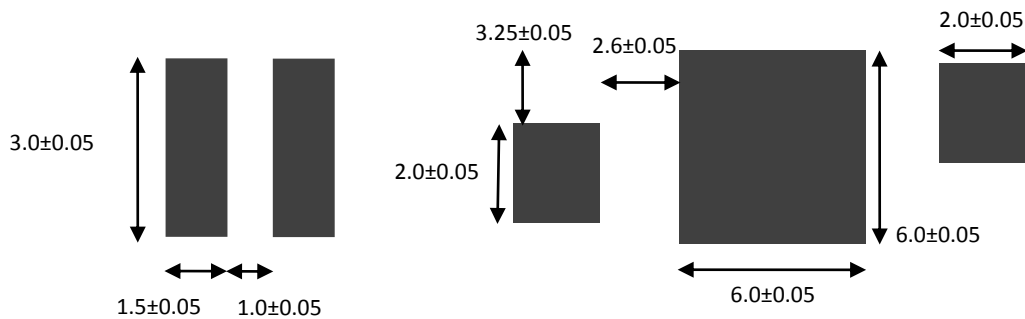

Note: Drawings are not to scale - to obtain values in inches, multiply by 0.04

* Please enquire with ElectrosPELL about availability of 3W package

Product availability and ordering information

Flat-white LEDs are available in the following packaging styles:

Low power (100 mW) LED
Surface Mount Device PLCC 3528 plastic package
[Corner depression identifies the cathode (-) terminal]
Product code: EWL4T12-SMD01



This product is also available in 1000 piece tape-and-reel packaging in moisture-sealed bags.

High power (1W and 3W) LED
Surface Mount Power LED package
[+ and – signs are engraved on anode and cathode legs]
Product codes: EWL4T12-P01 & EWL4T12-P03



This product is available in tube packaging.
This product is also available in 50 piece trays contained in moisture-sealed bags.

Handling information

Flat-white LEDs are static and moisture sensitive. Handle devices with appropriate precautions against electrostatic charge transfer to LEDs. Once a sealed LED package is open, reflow solder LEDs as soon as possible and in all cases within six months of package opening date. Baking devices before soldering is highly recommended and is essential if LEDs have not been stored in a dry environment. Recommended baking is at 110 °C for one hour or 70 °C for seven to eight hours.

To purchase Flat-white LEDs please contact ElectrosPELL using the following contact information.

ElectrosPELL/PRP Inc
4200 E La Palma Avenue
Anaheim
CA 92807
United States of America

Tel: (714) 528-5001
E-mail: sales@electrosPELL.com

For further information, please go to www.electrosPELL.com Copyright ©2012-2017 ElectrosPELL Limited.

Datasheet update date: June 03, 2017